

MODEL A / A

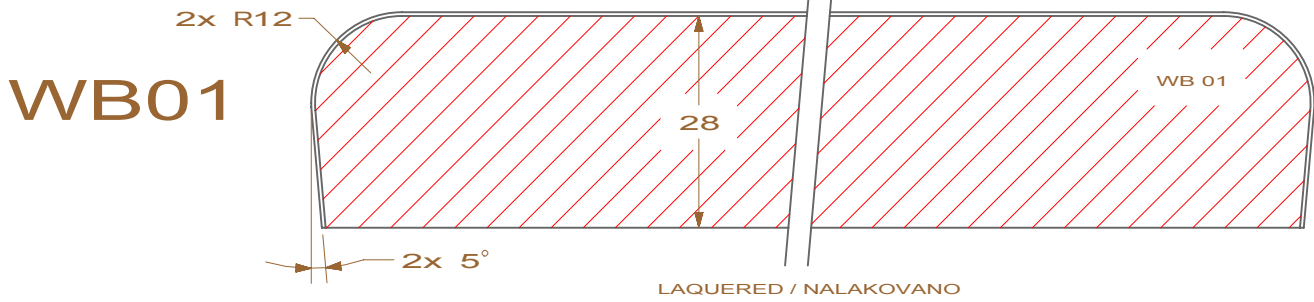

MODEL A / A

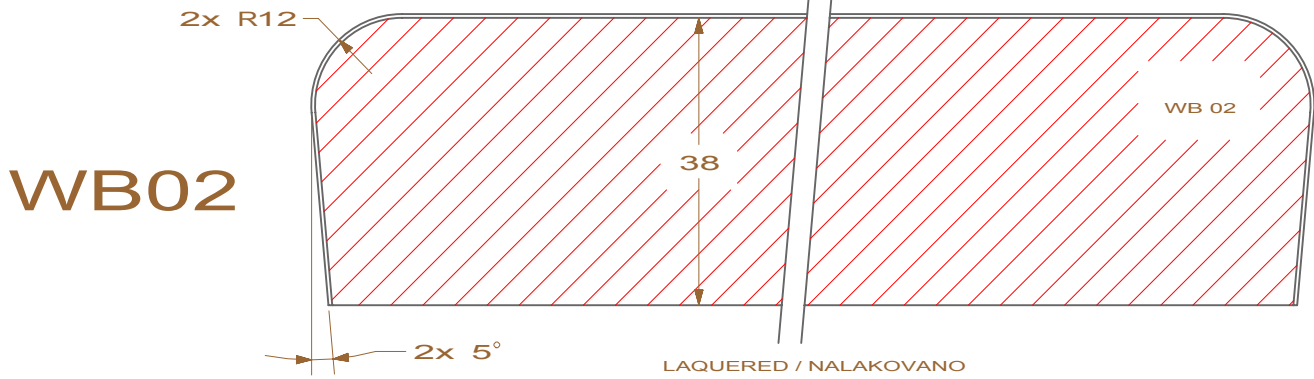

MODEL A

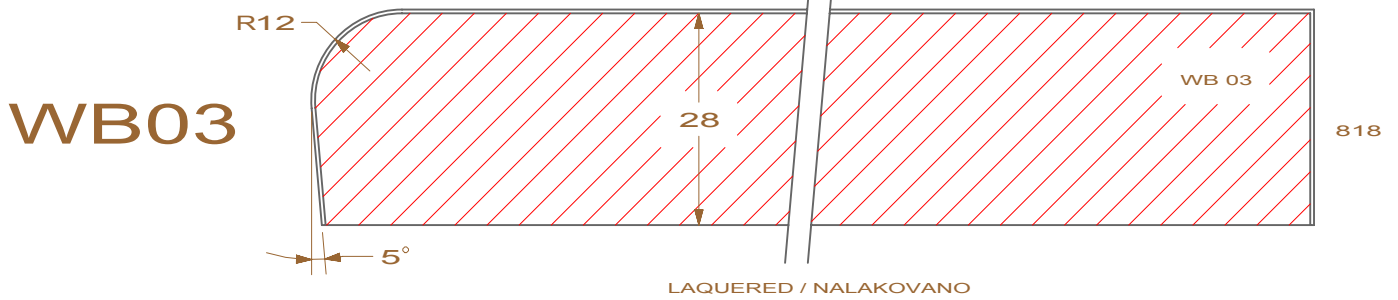

MODEL A

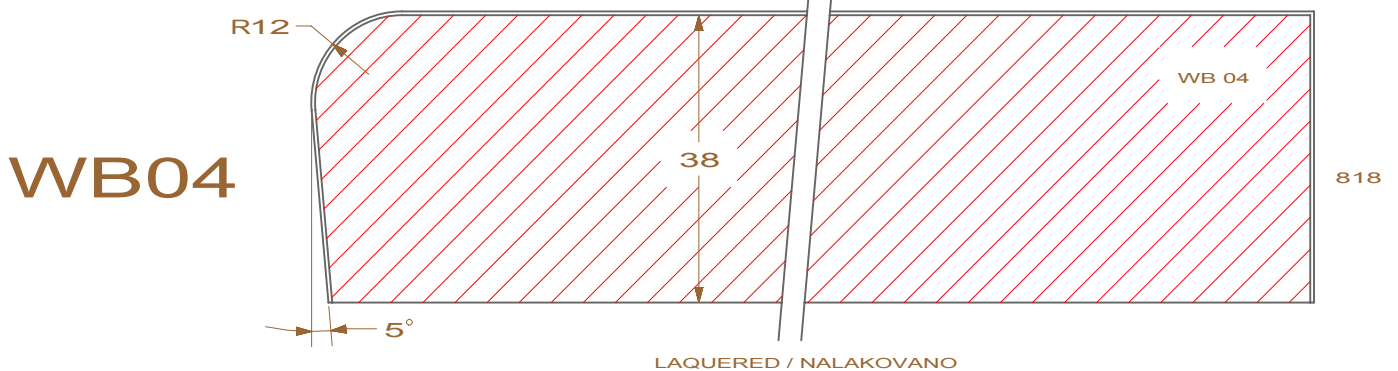

MODEL 180°

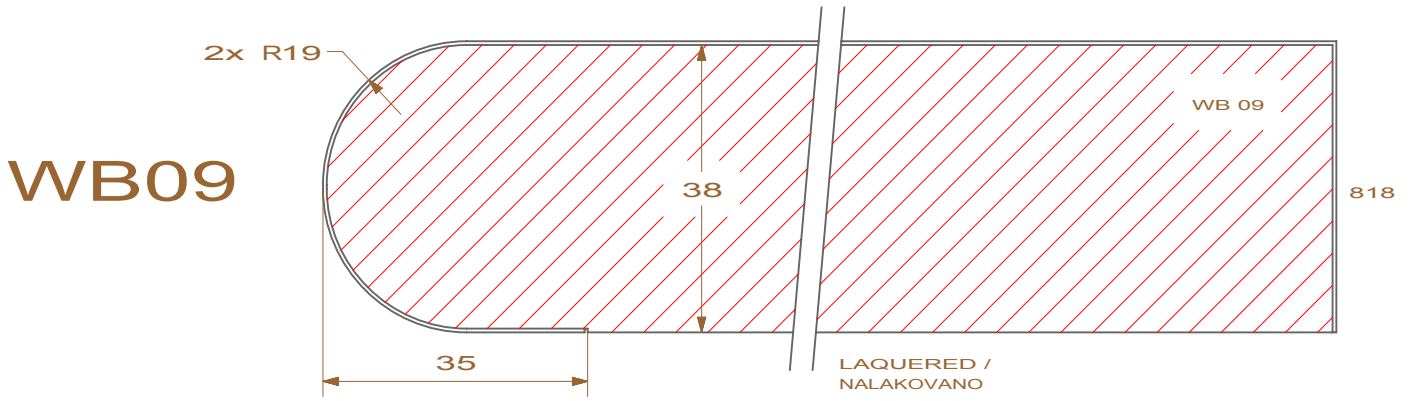

MODEL 180° / 180°

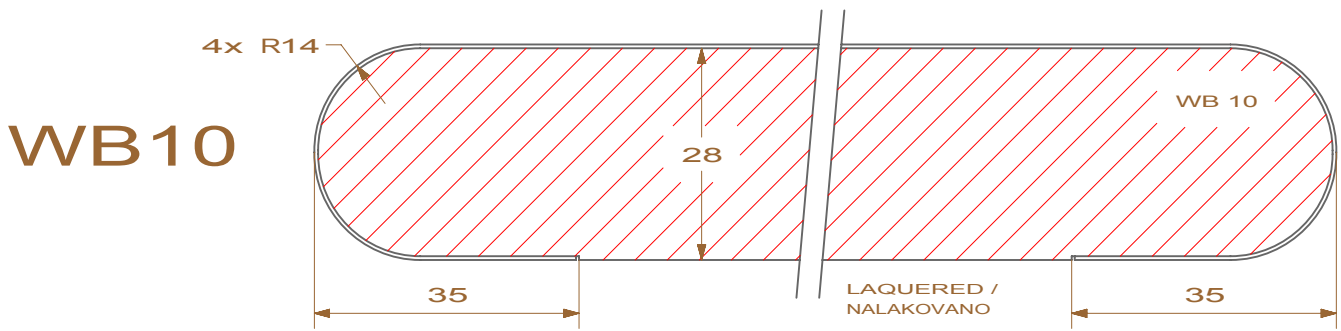

MODEL 180° / 180°

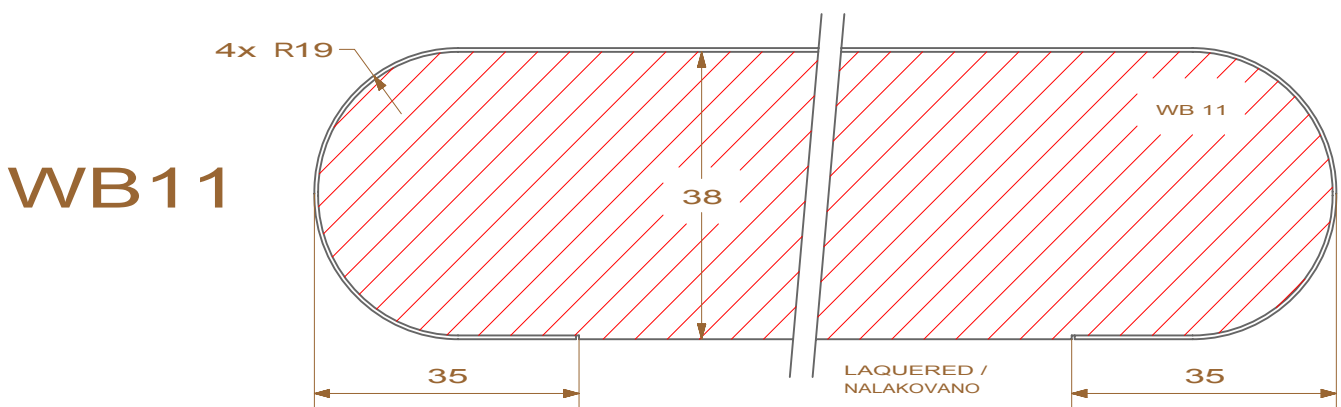

MODEL C

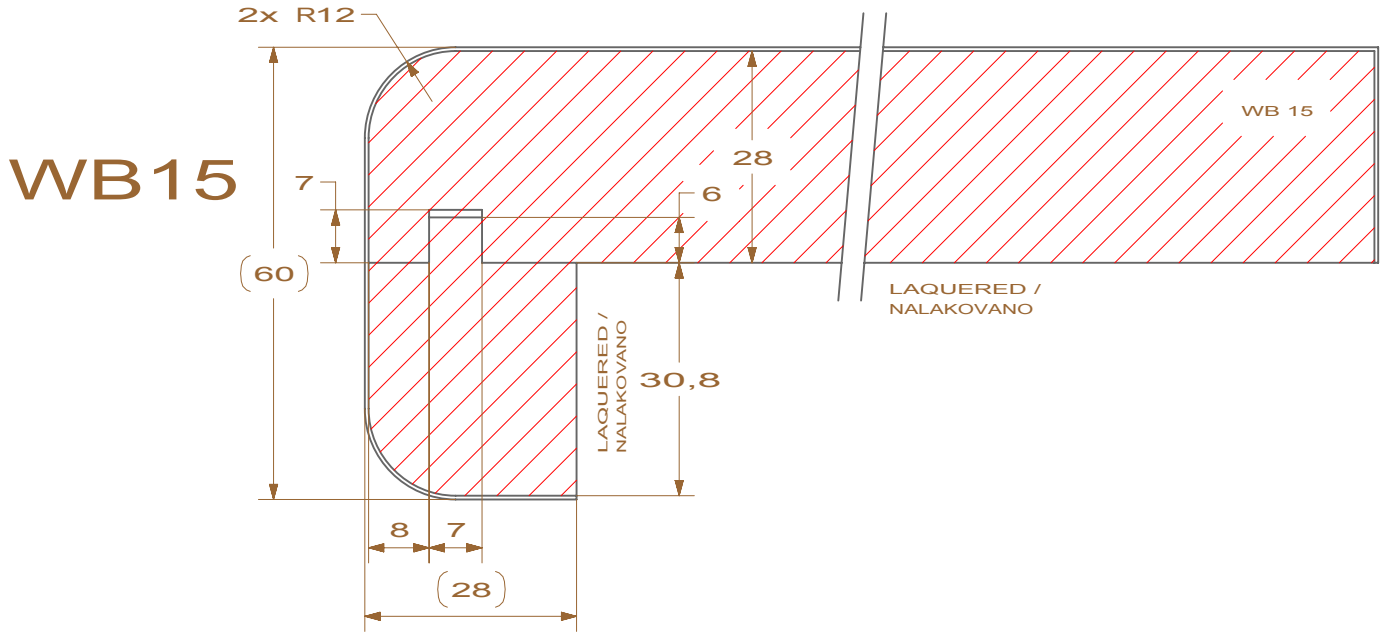

MODEL C / C

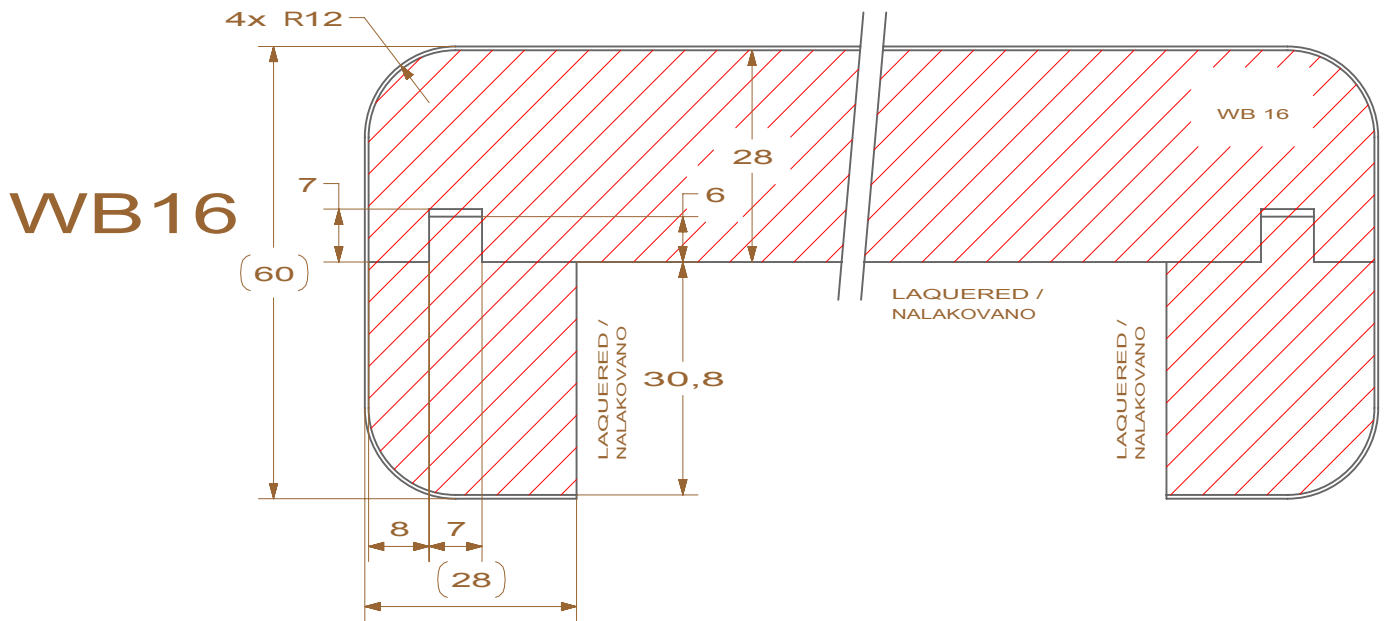

MODEL U

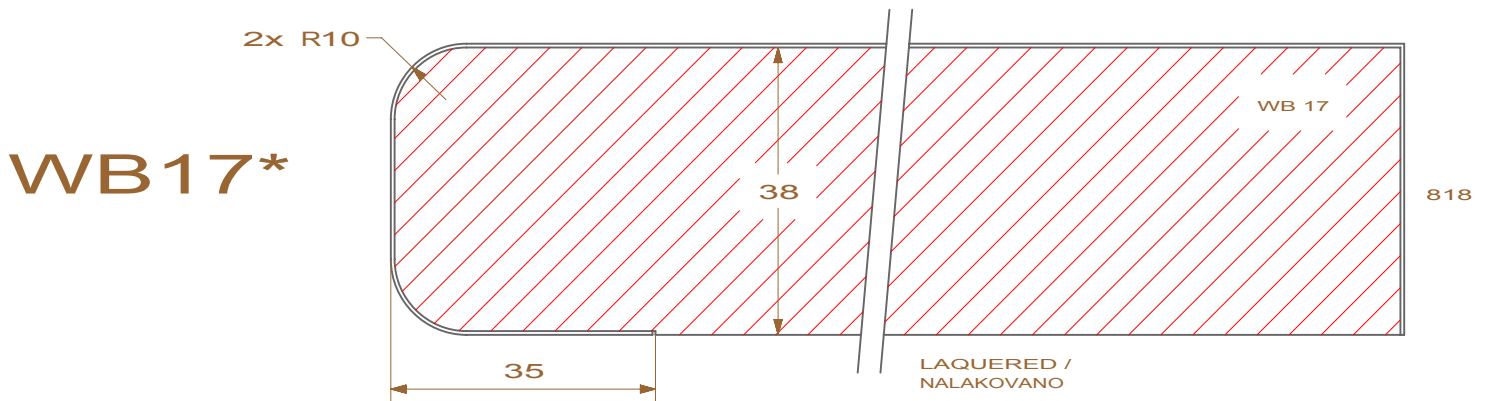

MODEL U / U

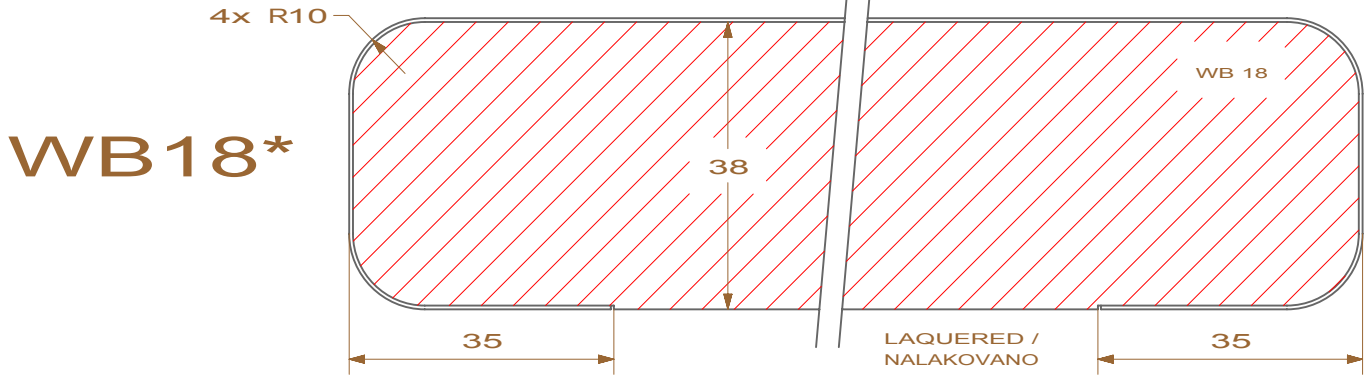

MODEL 180°

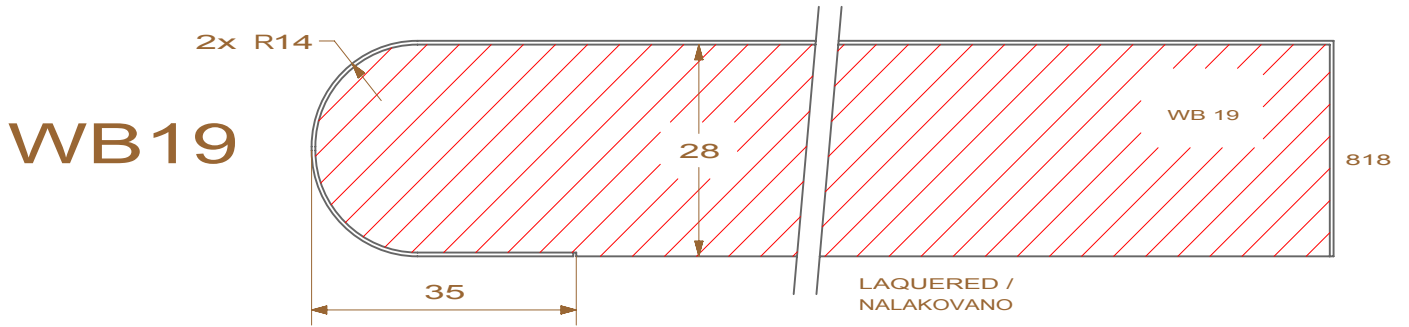

MODEL U / U

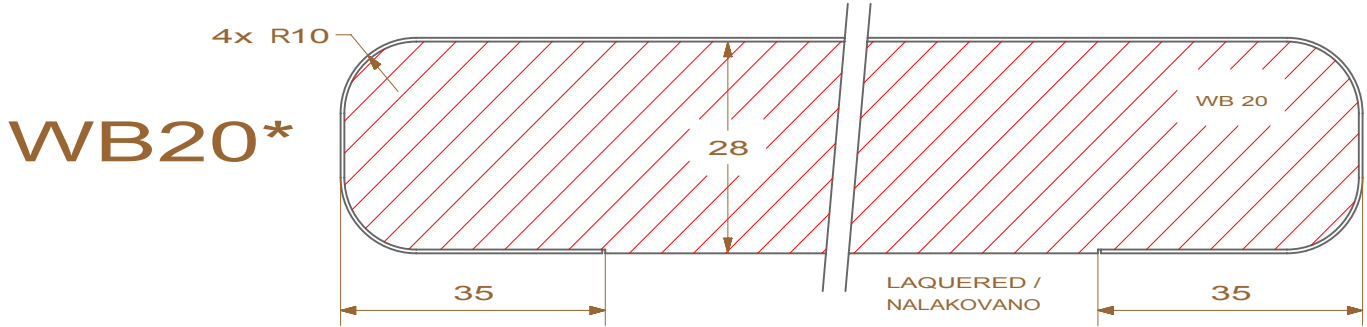

MODEL U

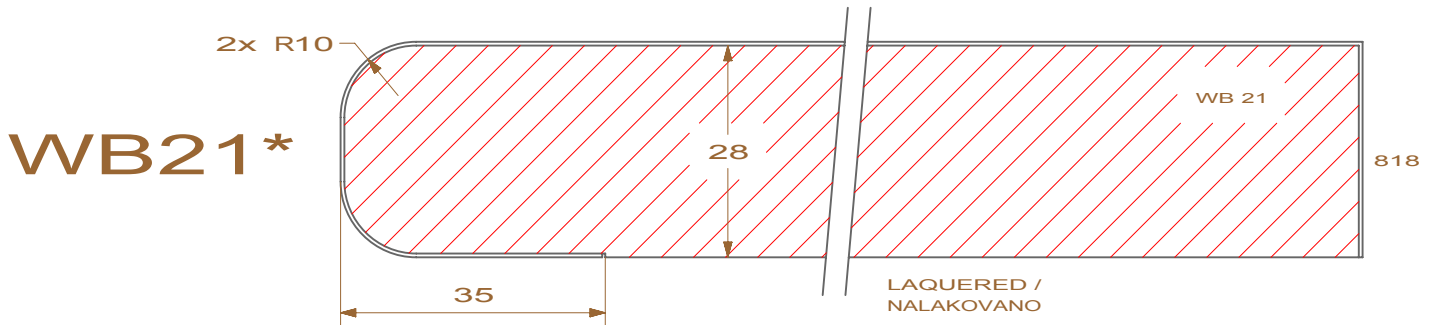

MODEL 180° / 180°

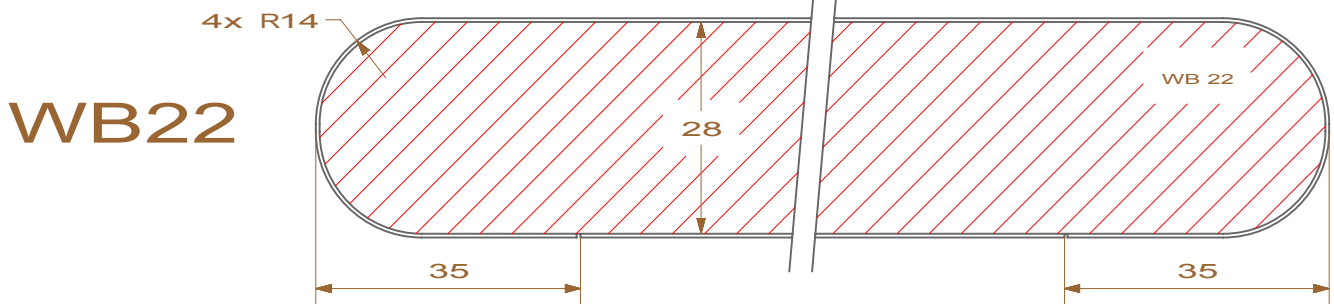

MODEL 180°

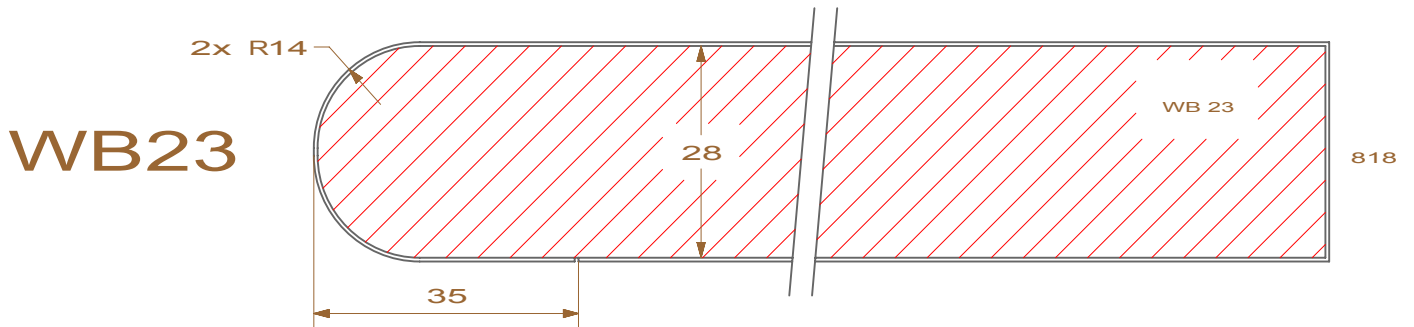

MODEL A

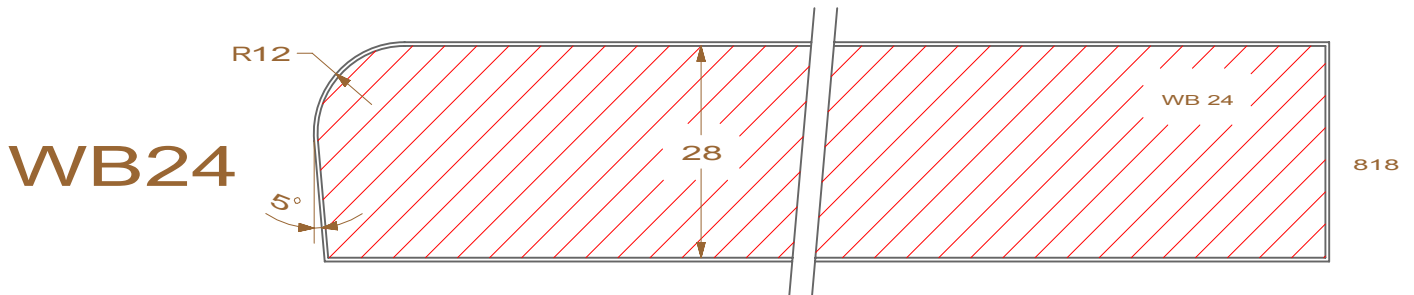

MODEL 180° / 180°

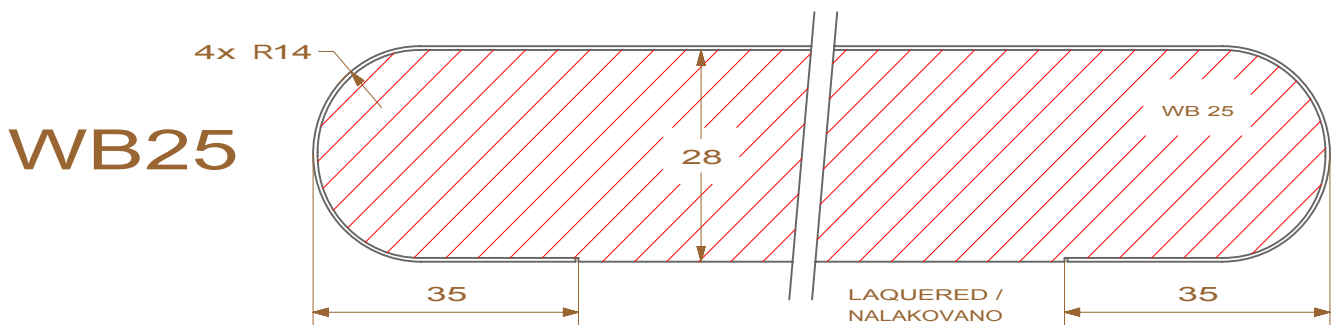

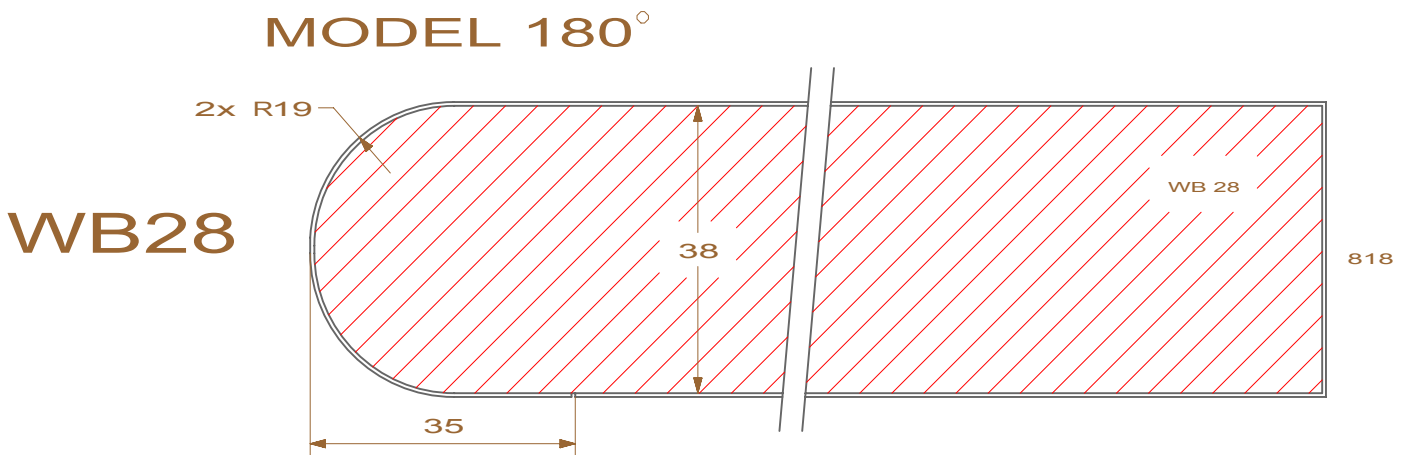
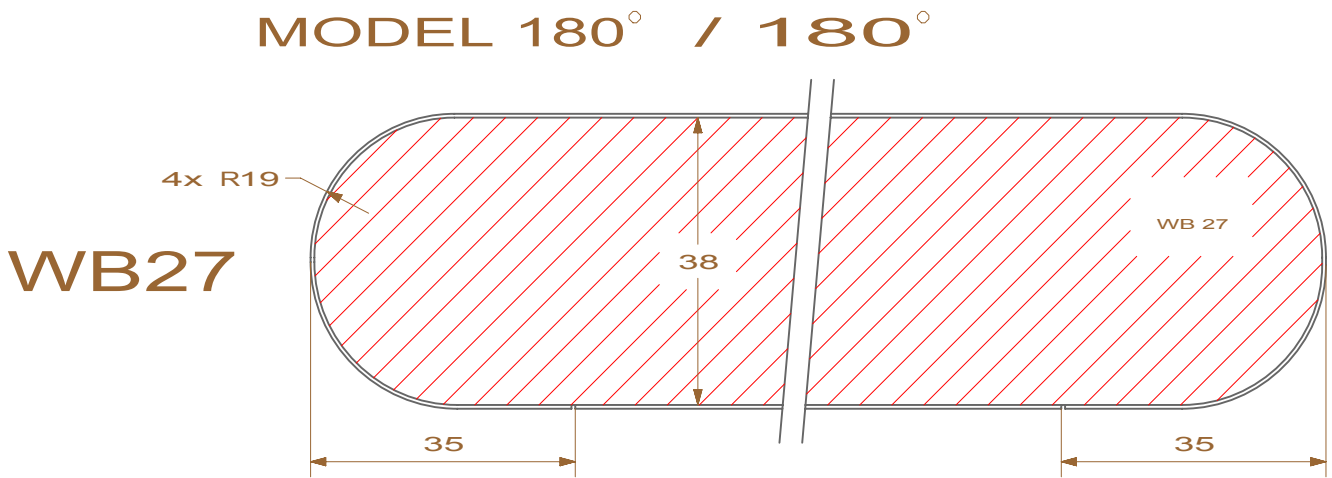
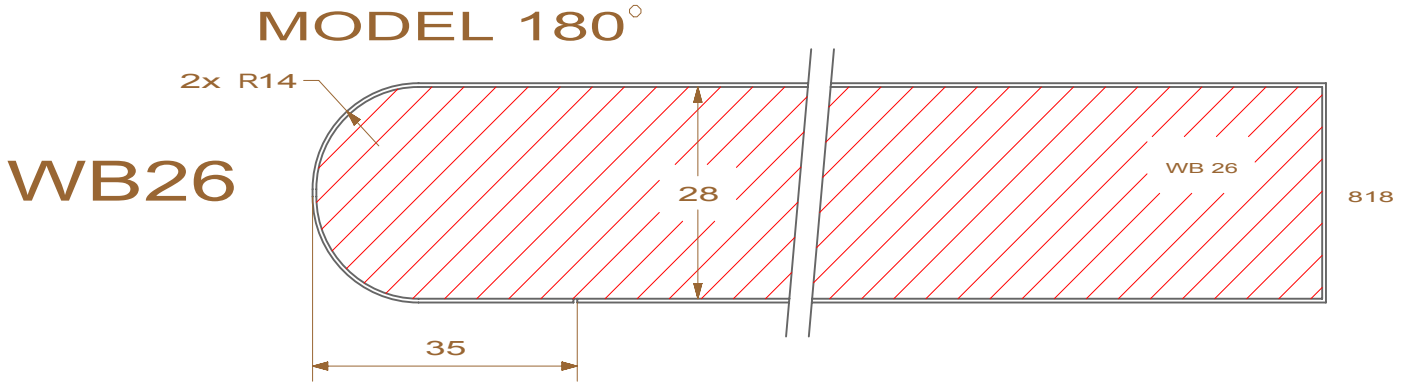

MODEL U

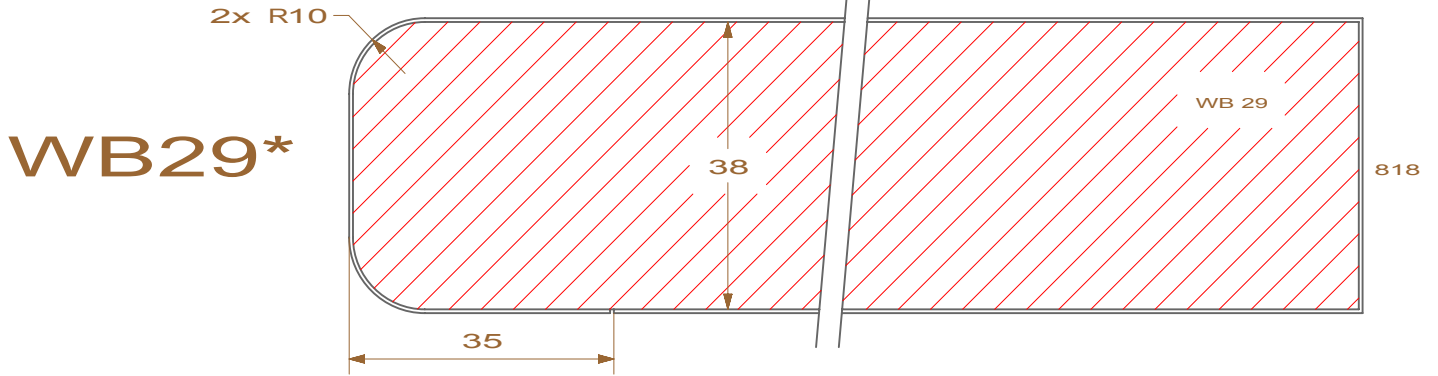

MODEL 180° / 180°

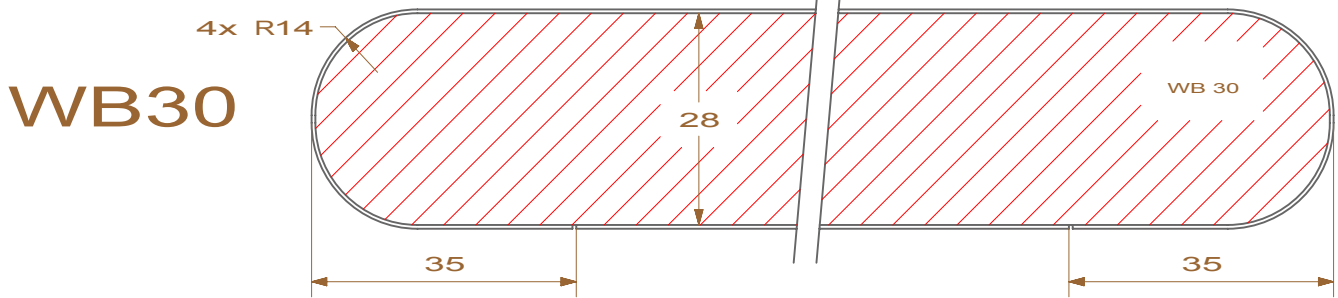

MODEL A

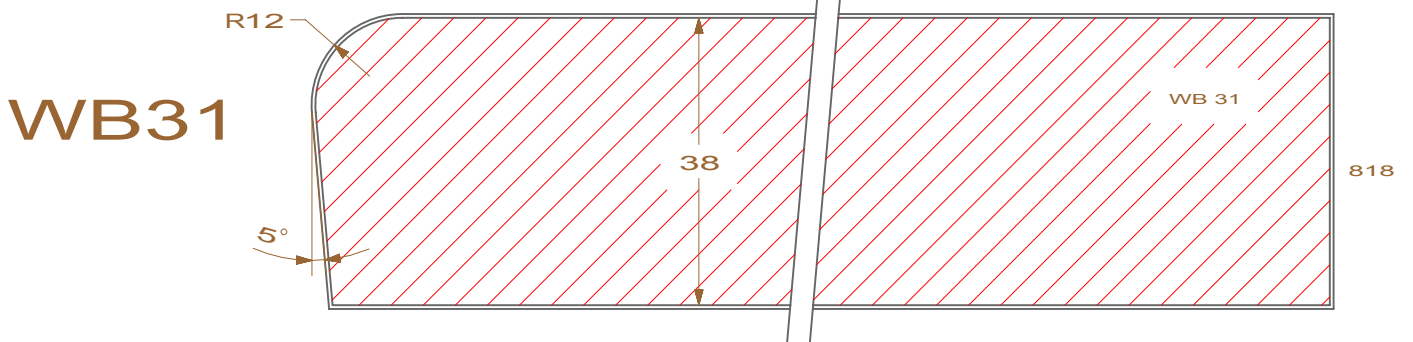

MODEL A

WB32

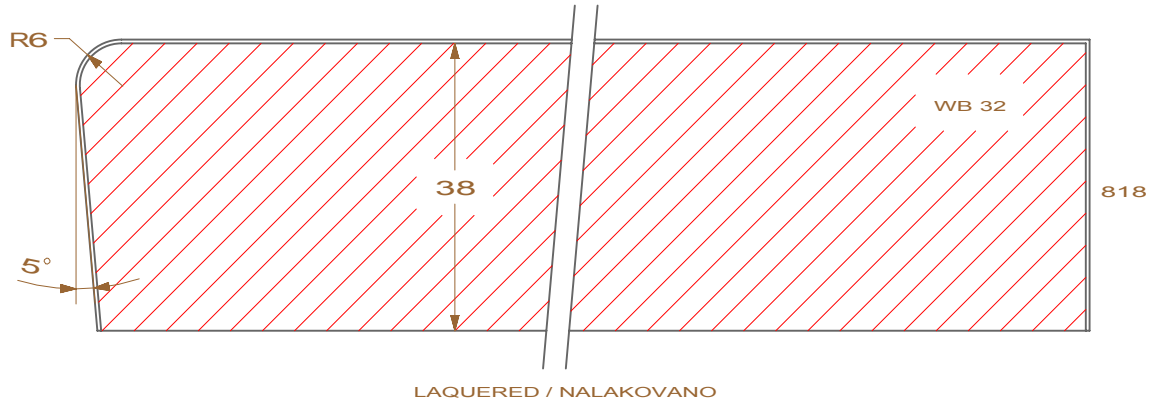

MODEL U

WB33

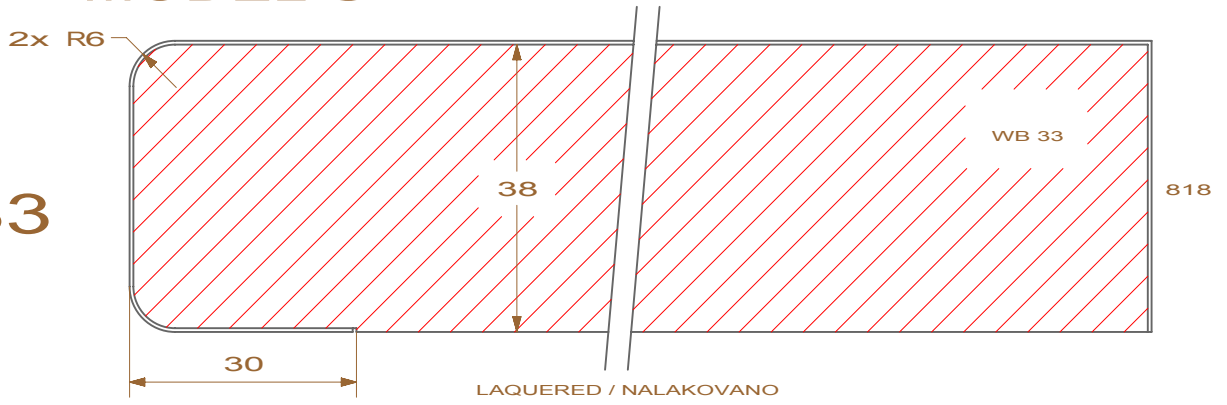

MODEL U / U

WB34

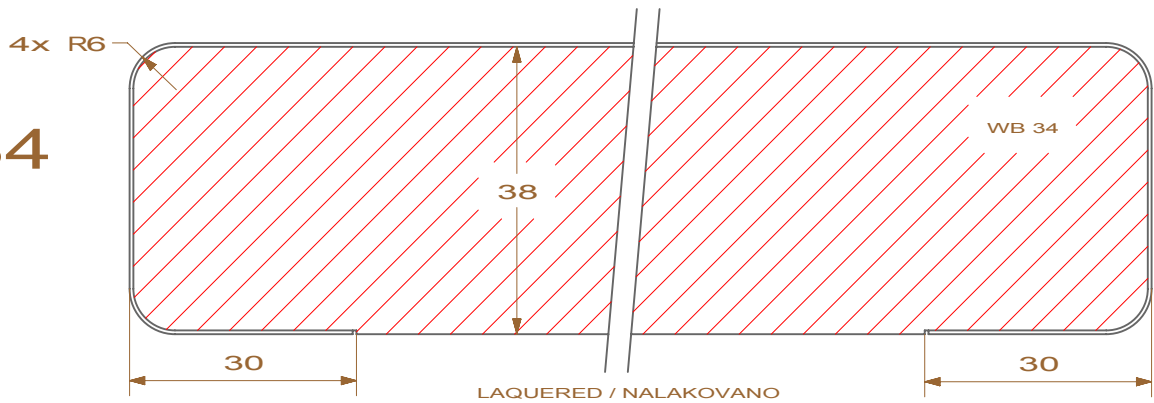

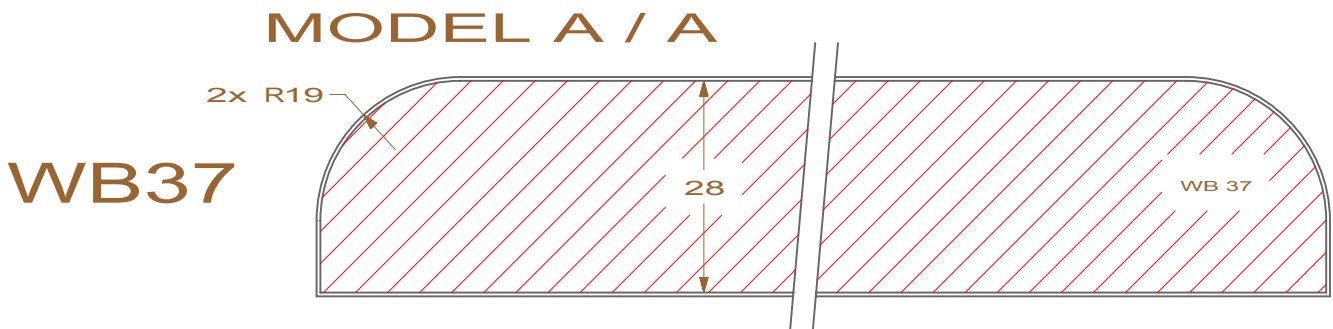
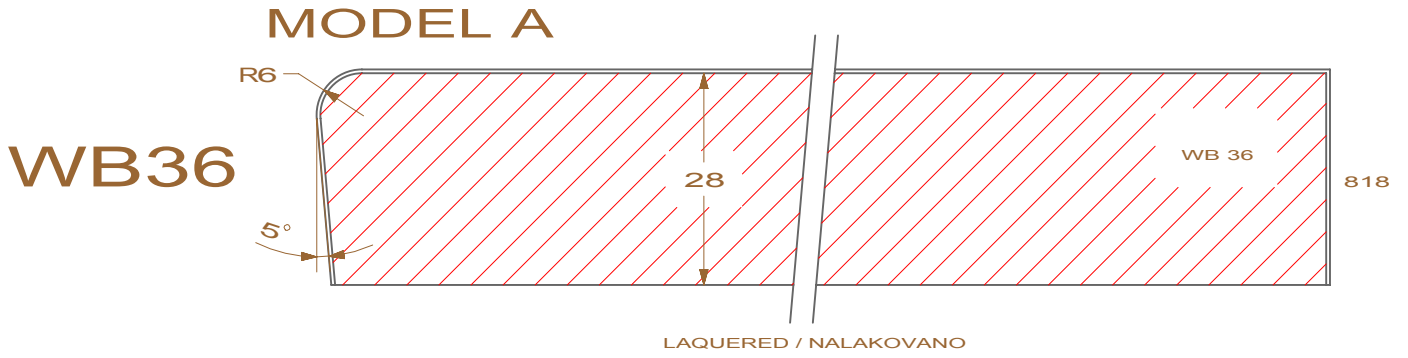
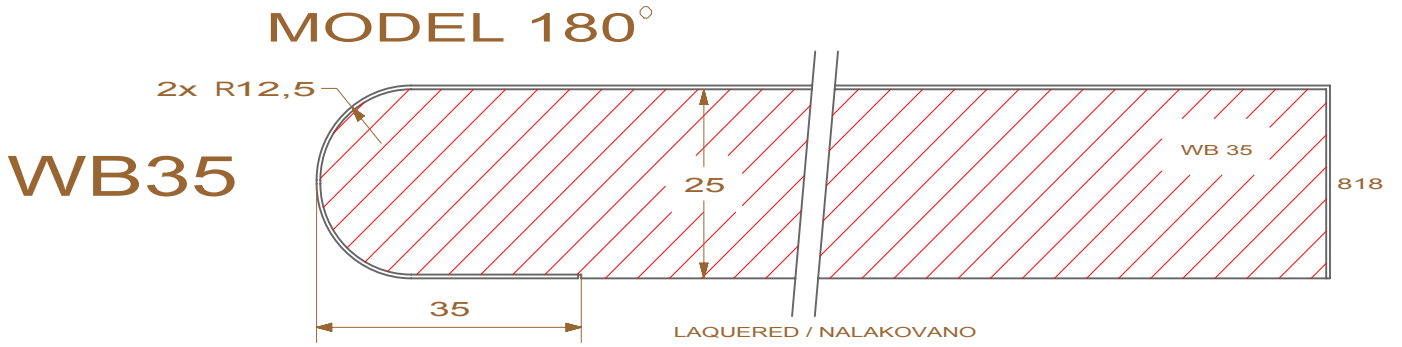

MODEL U

WB38

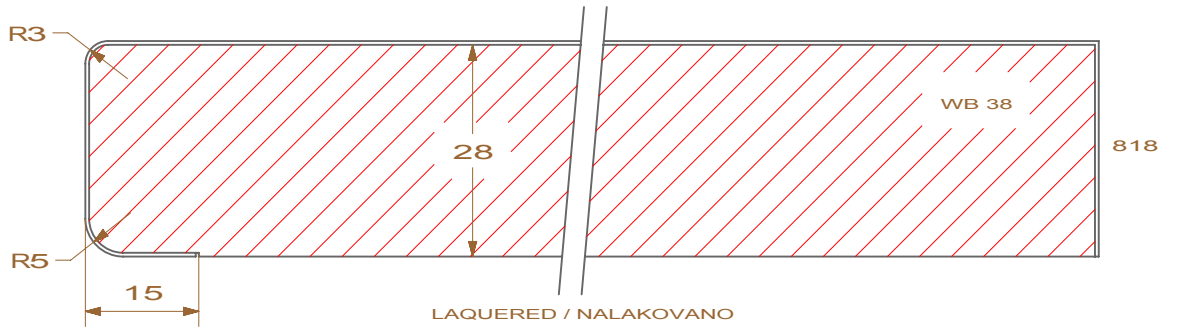

WB39

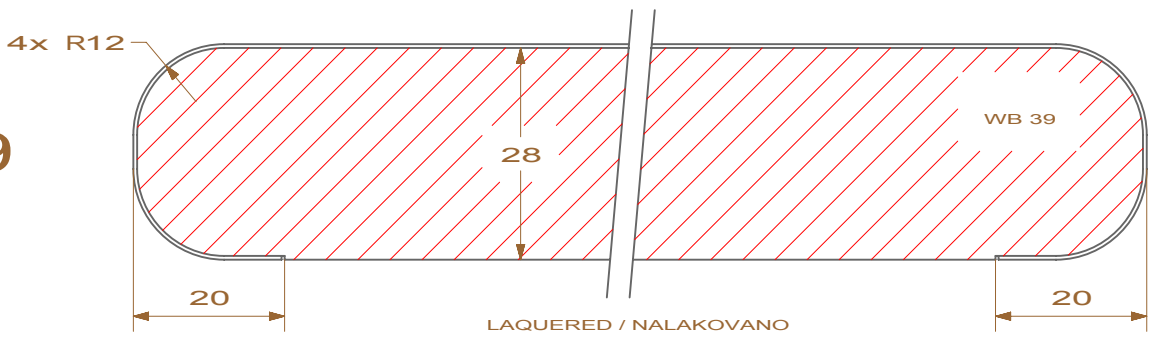

MODEL U

WB40

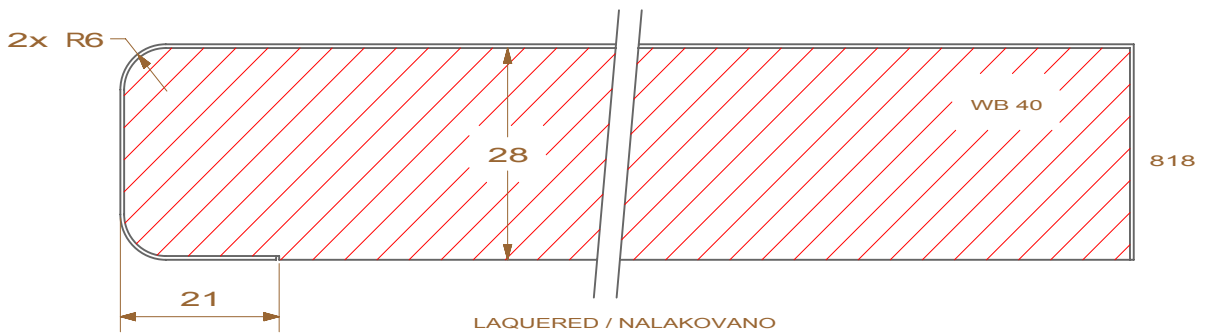

MODEL U / U

WB41

